Software Update & Rework Requirements

Bulletin Type:	Service Campaign Bulletin
Reference Number:	14 F 001
Campaign Reference:	04F
Attention:	Service Managers and Retailer Technicians
Affected Vehicles:	720S
Situation:	Service Campaign bulletin to address a number of concerns identified after vehicles left production.
Procedure:	Please refer to the instructions outlined in this document to complete the below checks/rework.
Date:	29 th August 2017

This bulletin will cover:

-
1. Software Update to Platform 4.4
 2. Engine Oil Level Check
 3. Front Brake Pad Wear Sensor Cable Re-routing
 4. Low Pressure Air Conditioning Pipe Securing

These checks/rework must be completed on all affected vehicles when carrying out Pre-Delivery Inspections (PDI) or at the next service centre visit.

1. Software Update to Platform 4.4

This software update changes the parameters in which the Transmission Control Unit (TCU) monitors the engine oil level and engine oil temperature.

Step 1:

Connect the Deutronic battery charger to the 12V battery

Step 2:

Connect the McLaren Diagnostic System (MDS) to the vehicle.

Step 3:

Select TCU (1), then Reprogramming (2), the software 14M0999CP_14 will be displayed. Proceed to the software download by selecting the arrow button (4).

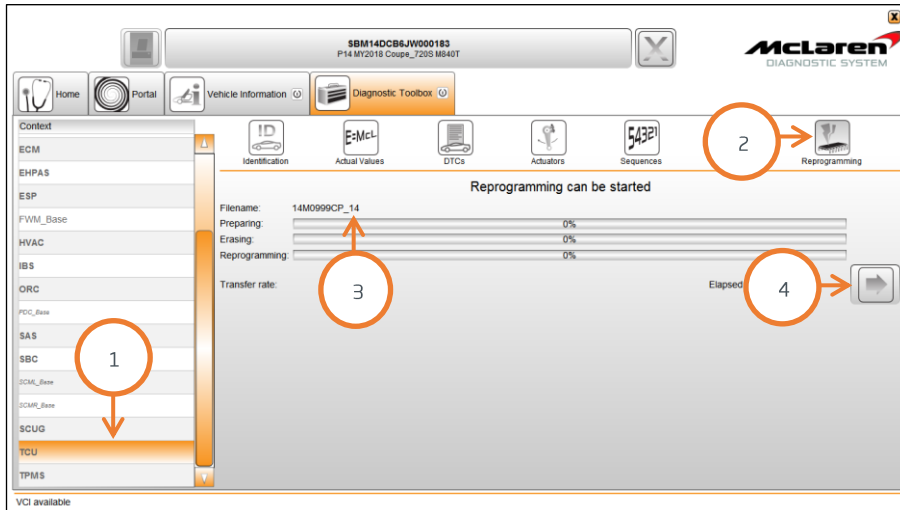

Step 4:

Once the software update is completed, select ADI (5), then Sequences (6), select the "Engine Oil Level Check Calibration" sequence (7).

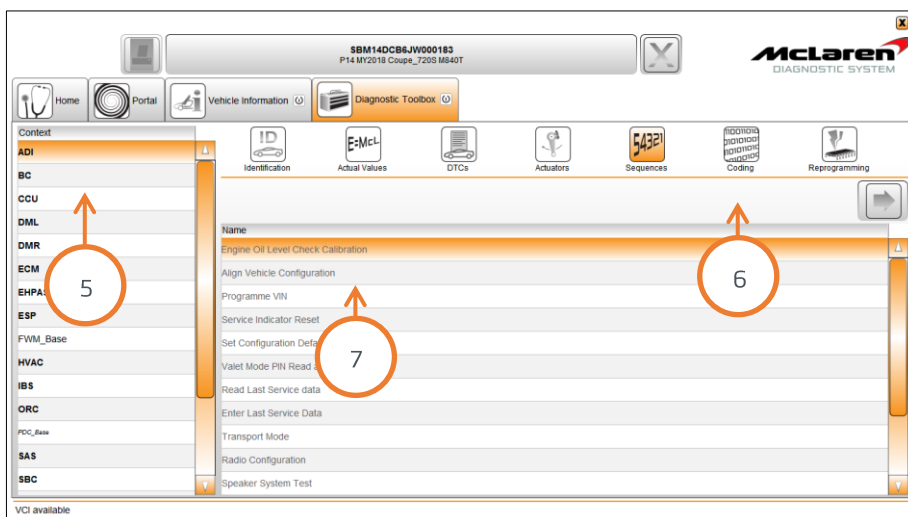

Step 5:
Ensure that all preconditions are met and then select OK (8).

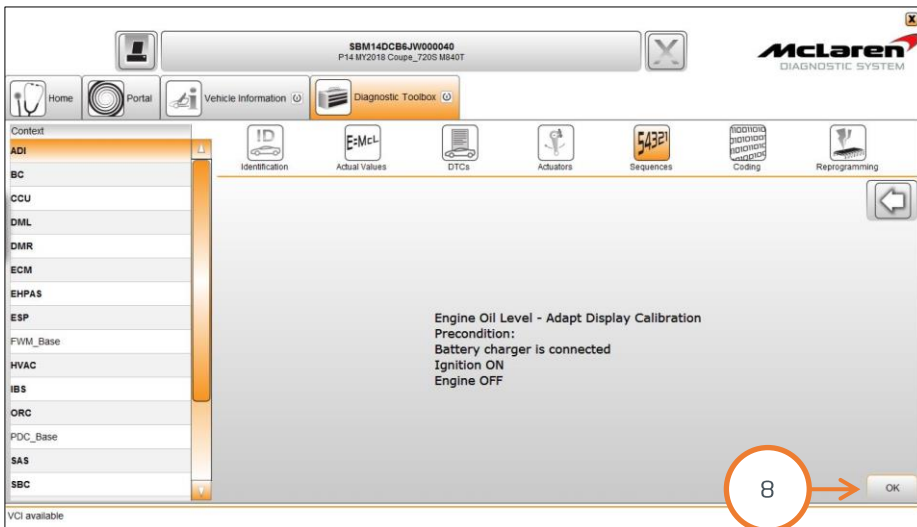

Step 6:
The purpose of this sequence is explained, select Yes (9) to continue.

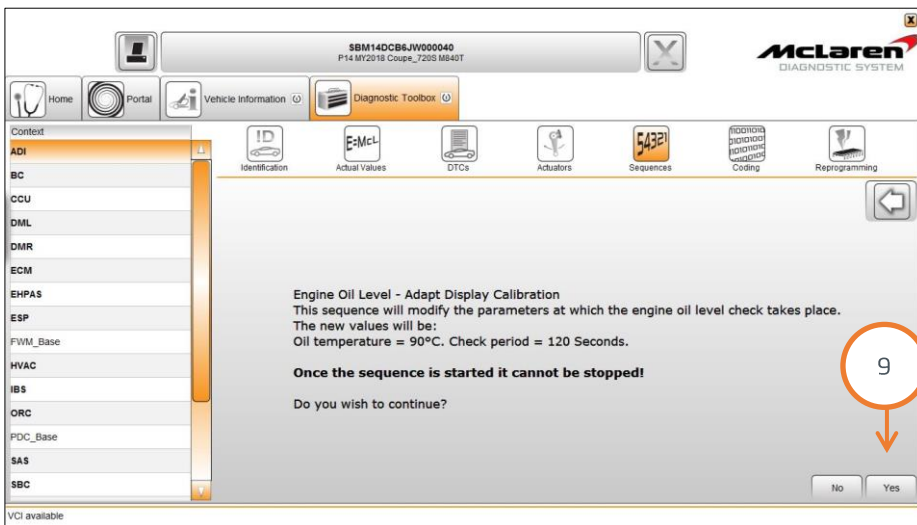

Step 7:
Once the sequence is completed, proceed to the Engine Oil Level Check section of this campaign.

2. Engine Oil Level Check

McLaren Automotive has identified that some vehicles may have left the factory with the engine oil level higher than normal, this may lead to severe engine damage if left unchecked.

Care Point: Please ensure that the Software Update - Platform 4.4 has been carried out prior to the engine oil level check.

Step 1:

Raise the vehicle on a lifting platform (refer to procedure DA-RM-01A001-00-001 - Secure/Lift vehicle on lifting platform on the Service Information System (SIS)).

Step 2:

Remove the engine floor panel (refer to procedure DA-RM-01A004-02-001 - Remove/Install floor panel - Engine on the SIS).

Step 3:

Using a suitable container, drain 0.5 litres of engine oil from the engine oil tank drain plug.

Care Point: The engine oil level check procedure will only function correctly when the engine oil temperature reaches 90°C (194°F) and for a duration of 120 seconds.

Care Point: Do not road test the vehicle until the engine oil level check is completed.

Step 4:

Run the engine and check the engine oil level via the Driver Display (refer to procedure DA-RM095F003-00-02- Check engine oil level on the SIS).

Step 5:

The engine oil level is correct when the Driver Display displays between 3 and 6 green segments (as shown below).



Step 6:

If the engine oil level check result is outside of the specified parameters, adjust the engine oil level as required.

The chart below provides the quantity of oil required based on the number of segments displayed.

Segments on the Drivers Display	Quantity of oil required
1 - red - under filled	0.90 litre
2 - amber - minimum	0.70 litre
3 - green - OK	0 litre
4 - green - OK	0 litre
5 - green - OK	0 litre
6 - green - OK	0 litre

Care Point: The vehicle must remain on the lifting platform with the engine floor panel removed, to perform the next action.

3. Front Brake Pad Wear Sensor Cable Re-routing

McLaren Automotive has identified that some vehicles may have the front brake pad wear sensor cable routed incorrectly, causing it to come into contact with the wheel when the steering wheel is turned on full lock.

Care Point: The check described below must be performed on both sides of the vehicle.

Step 1:

Turn the wheel to full lock.

Step 2:

Check the routing of the brake pad wear sensor cable (shown in red).

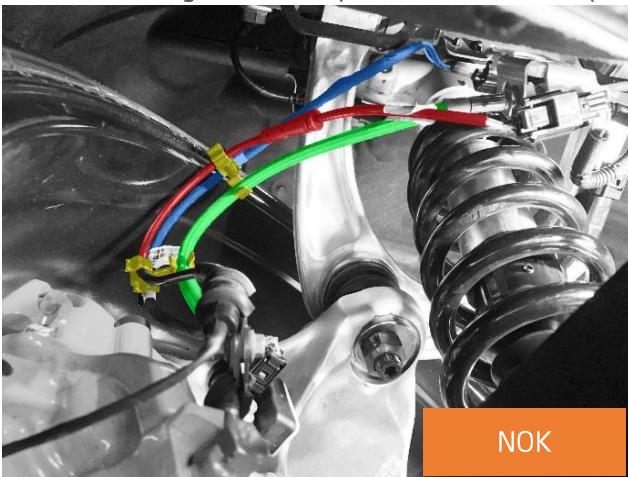

NOK - The brake pad wear sensor cable and clip are routed incorrectly, as they are above the brake pipe (shown in green).

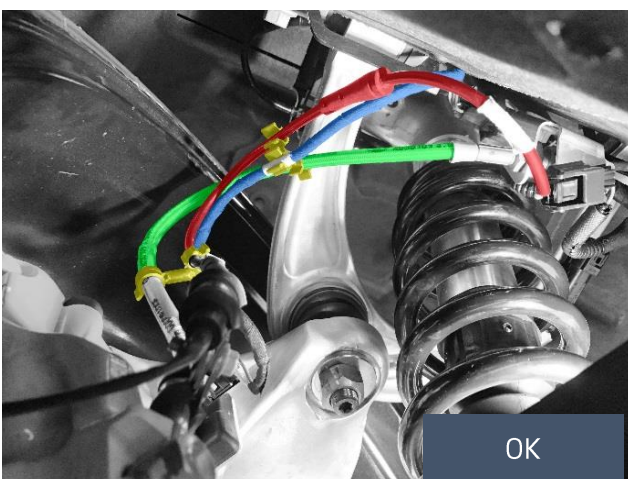

OK - The brake pad wear sensor cable and clip are routed correctly, as they are below the brake pipe.

Step 3:

If the routing of the brake pad wear sensor cable is **OK**, proceed to the next action "Low-Pressure Air Conditioning Pipe Securing".

Step 4:

If the routing of the brake pad wear sensor cable is **NOK**, proceed to step 5.

Step 5:

Disconnect the accelerometer sensor connector (1) and the brake pad wear sensor connector (2).

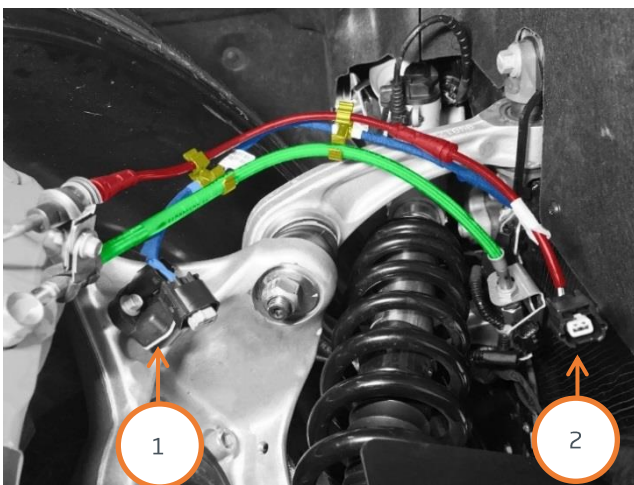

Step 6:

Ensure that both brake pipe clips (highlighted in yellow) are facing downwards. Re-fit the brake pad wear sensor and accelerometer cables onto the clips, routing them so that they are below the brake pipe and away from the wheel.

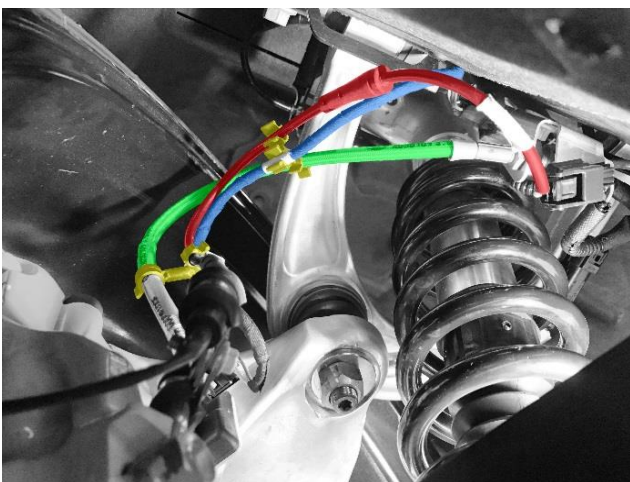

Step 7:

Reconnect the brake pad wear sensor and the accelerometer connectors ensuring any cable excess is towards the tub.

Step 8:

Turn the wheel to the opposite full lock and check that the brake pad wear sensor and accelerometer cables are not touching the wheel.

Care Point: The vehicle must remain on the lifting platform with the engine floor panel removed, to perform the next action.

4. Low-Pressure Air Conditioning Pipe Securing

McLaren Automotive has identified that the firtree cable tie which secures the low-pressure air conditioning pipe was not fitted. If left unchecked a clash with the coolant hose may occur.

Step 1:

Fit a new firtree cable tie 00RL001 into the respected hole in the left rear side of the frame (1).

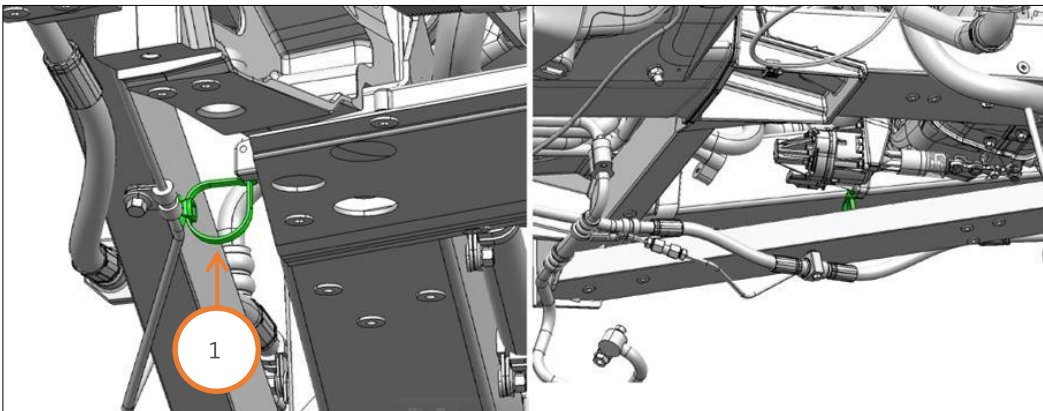

Step 2:

Ensure that the low-pressure air conditioning pipe (2) is correctly secured to the firtree cable tie. Using a pair of pliers, pull the firtree cable tie to tighten, ensuring that there is no play in the firtree cable tie to the air conditioning pipe prior to snipping the excess off the firtree cable tie.

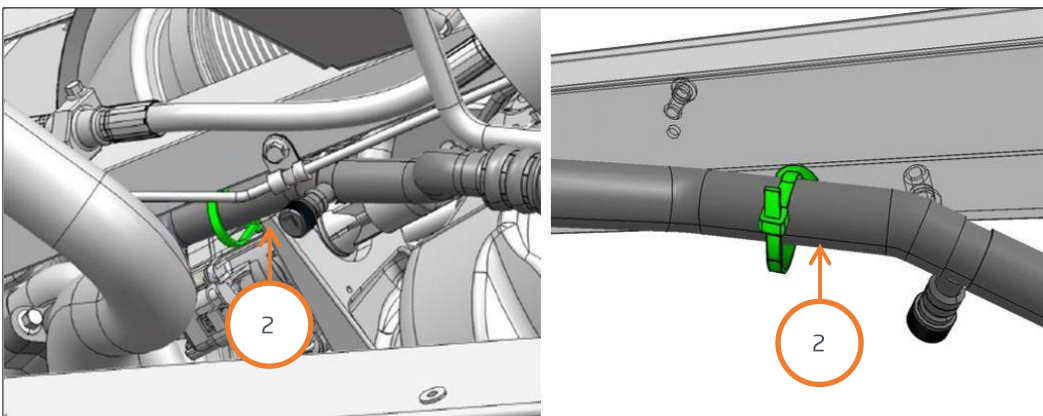

Step 3:

Once all the above re-works have been completed, re-install the engine floor panel.

If you have any questions, please speak to your Regional Aftersales Manager.

Best regards,

The information contained in McLaren bulletins is for internal use only by McLaren Authorised Retailers and must not be published on any external website or social media, or public.

The information contained in McLaren bulletins are for internal use only by McLaren Authorised Retailers and must not be published on external website or social media forums etc.

All bulletins (Information/Campaign/Recall) issued by McLaren Automotive Limited ("McLaren") are intended only for use by technicians who have attended McLaren technical training courses. McLaren trained technicians have the equipment, tools, safety instructions and the know how to perform the job properly and safely. McLaren Bulletins are written to inform McLaren technicians of conditions that may occur on some McLaren vehicles, or to provide information that could assist diagnosing a McLaren vehicle. Part numbers listed in McLaren bulletins are for reference only. Always check with the parts department to verify the latest part numbers.

Warranty Information

Description	Resolution Code	Repair Time
Multiple Repairs	CPCPC402A11A9902	1.7 Hours

Parts Information

Description	Part Number	Quantity	Order Process
Firtree Cable Tie	00RL001	1	Unipart