

Document Information

Location: Powertrain

Topic: Missing core plug from cylinder head on V8 engines only

Condition: Permanent

Diagnostic Trouble Codes: N/A

Measure

In the event you are presented with an engine making a noise resembling a blowing exhaust [video link], please proceed to check the core plugs for the secondary air injection (SAI) on the cylinder heads.

Should you find one of the core plugs are missing, please work through the following steps to replace the missing core plug.

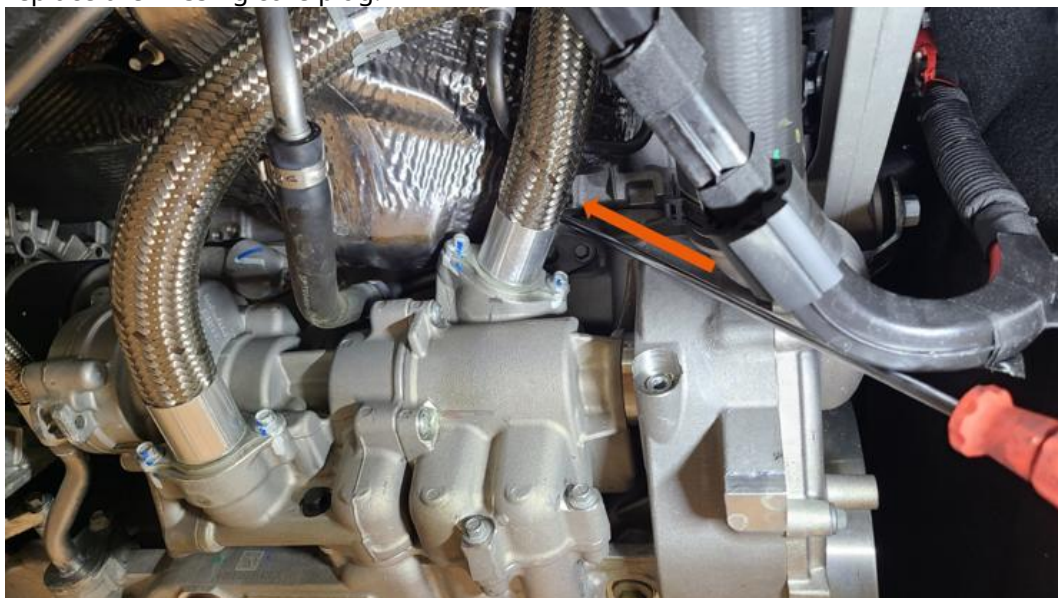



1. Check and identify the missing core plug and document its location e.g. bank 2 cylinder 6 and capture clear images from distance and close up
2. Using a UV torch, identify if there is any adhesive present in the core plug bore. It should glow under UV light. Capture a supporting image of this check
3. Please submit a TR titled 'V8 Missing Cylinder Head Core Plug' with images of the missing core plug, UV check for adhesive, documents as per TR submission standards and a clear description of where the core plug is missing

Care Point: A new 8mm core plug will be sent to your Retailer so please include your shipping information in the TR - Retailer address, contact name, contact email, contact phone number, VAT and EORI numbers where applicable

Core Plug Replacement

4. Clean the core plug bore using brake cleaner and a lint free cloth
5. Apply sealing agent (see parts information for options) to new 8mm core plug and press into cylinder head using a suitable punch that matches the ID of the core plug base until top surface sits 3mm (+/- 1mm) below cylinder head surface. Please see image below

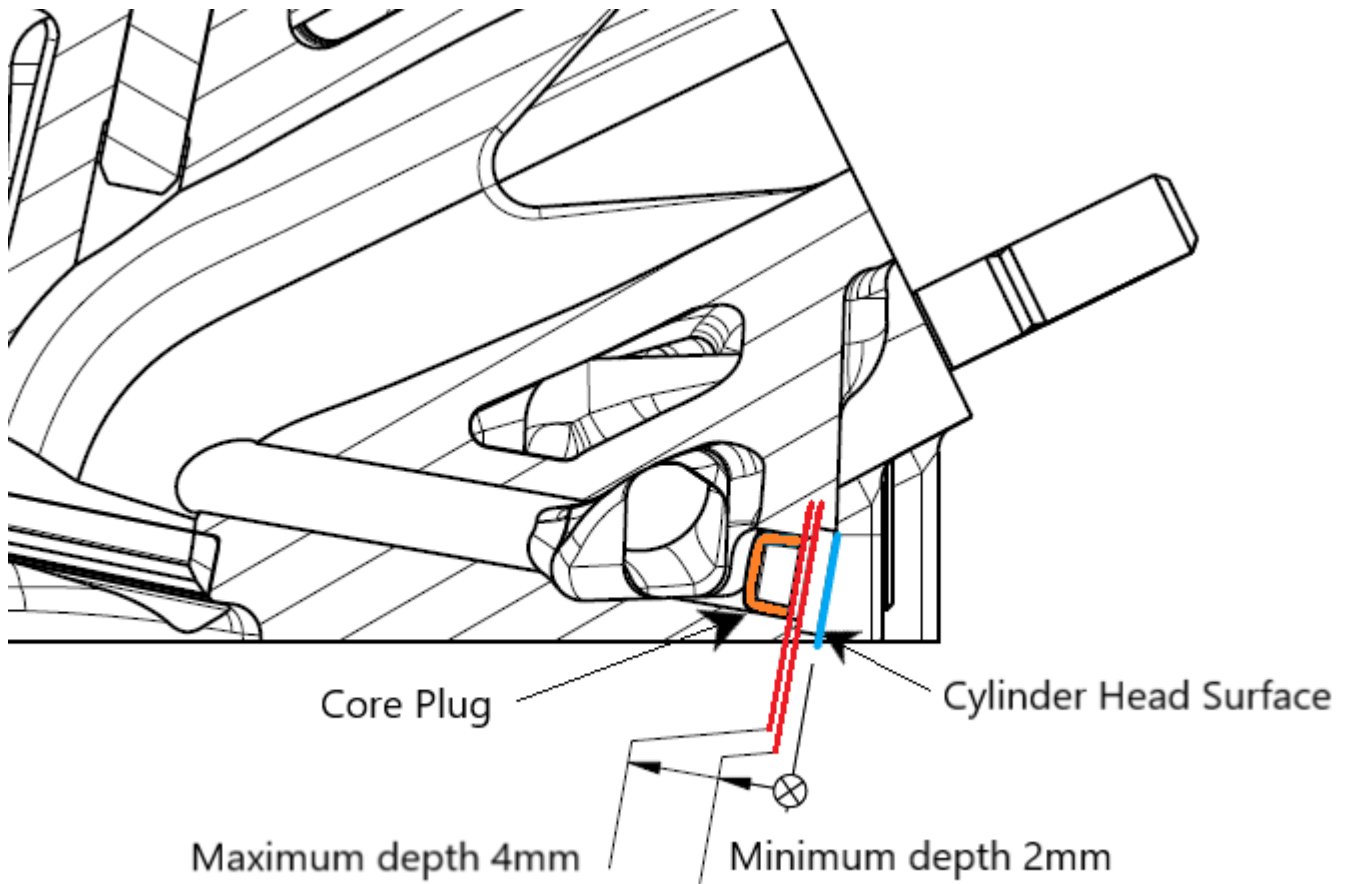

6. Allow 24 hours for sealing agent to set before running the engine

Parts Information

8mm Core plug – to be supplied via TR

Loctite 648 – Sourced locally

Threebond 1375B – Sourced locally

Associated parts relating to components removed to complete the repair

Care Point: If Loctite 648 and Threebond 1375B are both not available in your region, please source an alternative with the same specification and submit the product details on the TR to be reviewed before using.

Attachments

N/A

KA Update Information

1/10/2025 – Initial release