

This document is uncontrolled when printed. Before use, check the Knowledge Base within the McLaren Retailer Portal to verify that this is the current version.

## Description

Body BIW – Active Aero – P14: 720S, 720S Spider, 765LT – Follow the instructions available in this article to install an external catch tank in the event of a customer complaint for persistent issues with the airbrake system even though KA-01105 has been completed on a previous visit

## Document Information

Location: Body BIW – Active Aero

Topic: Airbrake Warning Message On Driver's Display

Condition: Permanent

Diagnostic Trouble Codes : N/A

TCU:

C101B92 Airbrake move time out

C101C92 Airbrake movement implausible

C101A94 Airbrake not holding position

## Measure

The level of the clutch fluid when is not being pumped around the transmission can sit lower than the airbrake deploy valve (see image below) within the transmission.

When the engine is running so is the oil pump in the transmission, which will distribute the oil covering the deploy valve stopping the risk of introducing air.

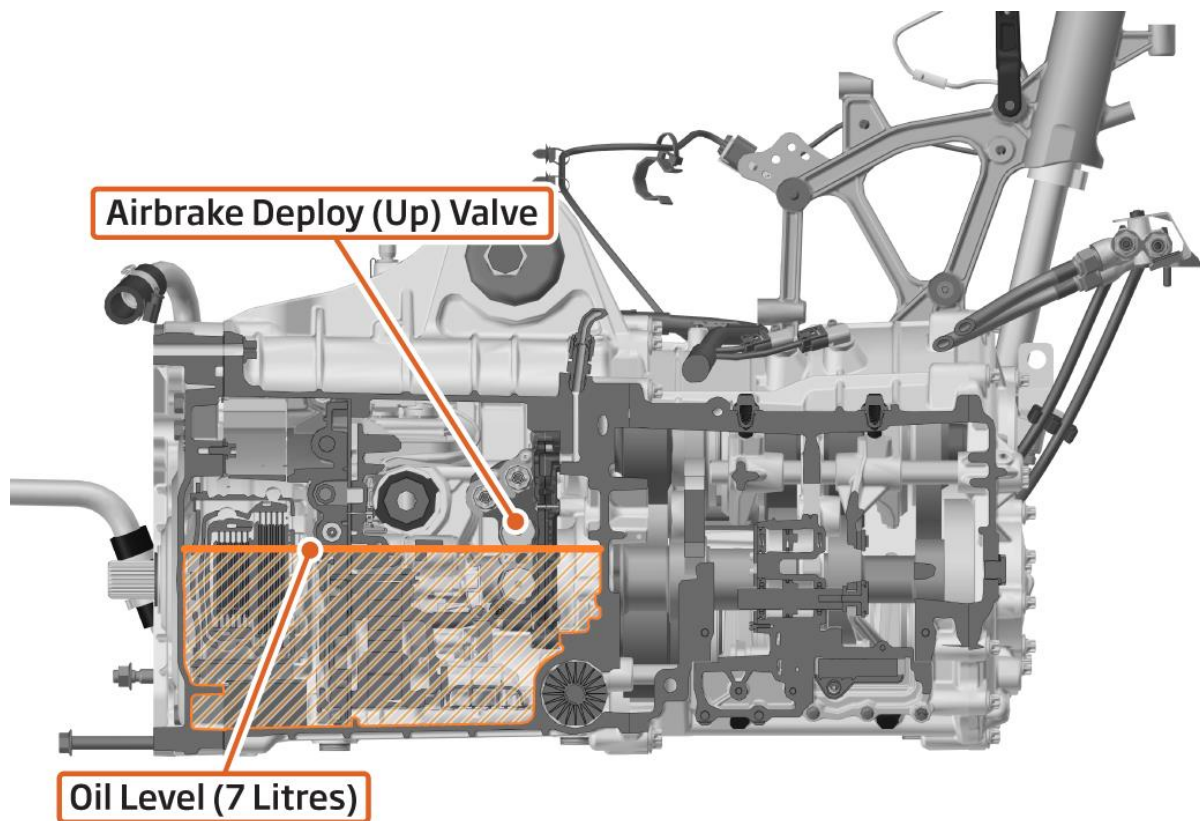

However, there can be various driving and airbrake deployment conditions that could still allow the system to pull through clutch fluid and air. The presence of air in this hydraulic system can result in reduced functionality of the airbrake followed by airbrake warnings and DTCs being registered as outlined in the 'Diagnostic Trouble Codes' section above.

In order to eliminate the possibility of this occurring, it is advisable to retrofit an external clutch fluid catch tank. Ultimately, this will allow for an increase in the clutch fluid fill which will result in a higher clutch fluid level in the transmission without causing leaks from the breather valve.

**Care Point:** Prior to the installation of the catch tank, ensure KA-01105 has been carried out first.

The procedure for installing the catch tank and adjusting the clutch fluid level accordingly can be found below:

1. Drain the clutch oil (as per SIS instructions) and measure the quantity
2. With the transmission still in the vehicle, remove (pull out) the existing breather valve (No. 8 in the graphic below)

3. Then remove (unscrew) the plug located at the opposite end (No. 3)
4. Once both plugs have been removed proceed to the installation of the new assembly
5. Push in the No8. end of the breather into the location where the original breather valve was (removed at step 2)
6. Then insert the banjo end to the other end (do not torque at this stage), where the screw was (removed at step 3)
7. Then insert the middle bit of the assembly (highlighted in yellow) into the casing of the transmission
8. Ensure the assembly sits nicely with no tension
9. Once satisfied that the above steps have been completed successfully proceed to torque the banjo bolt to 15Nm
10. Then torque both grub screws (No.9) to the casing of the transmission, use 2.5Nm.
11. Ensure No. 8 end is fully inserted

Once the installation is completed, refill the clutch (as per SIS procedure) BUT the clutch fluid level MUST be increased by 700ml compared to the instructions.

Once the clutch fluid fill procedure, including the increase of 700ml, has been completed carry out the following sequences using the MDS diagnostic tool:

1. Airbrake bleed sequence
2. Sleep the vehicle
3. Airbrake calibration sequence
4. Sleep the vehicle
5. Clear DTCs

Finally test the operation of the airbrake by means of a test drive to confirm successful completion of the job.

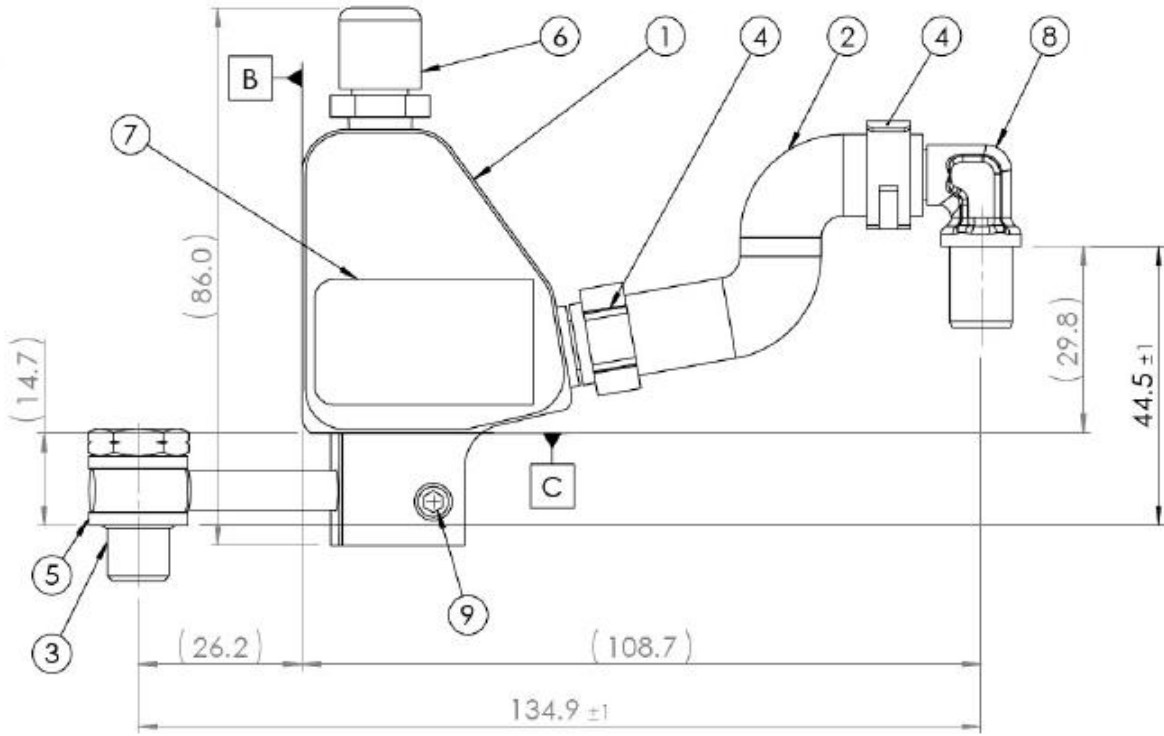

Remove the clutch breather from the DCT

This may require gentle heating with a hot air gun to remove

The breather tank then fits into the hole

Fit the catch tank front line to the front interface plate connection thread

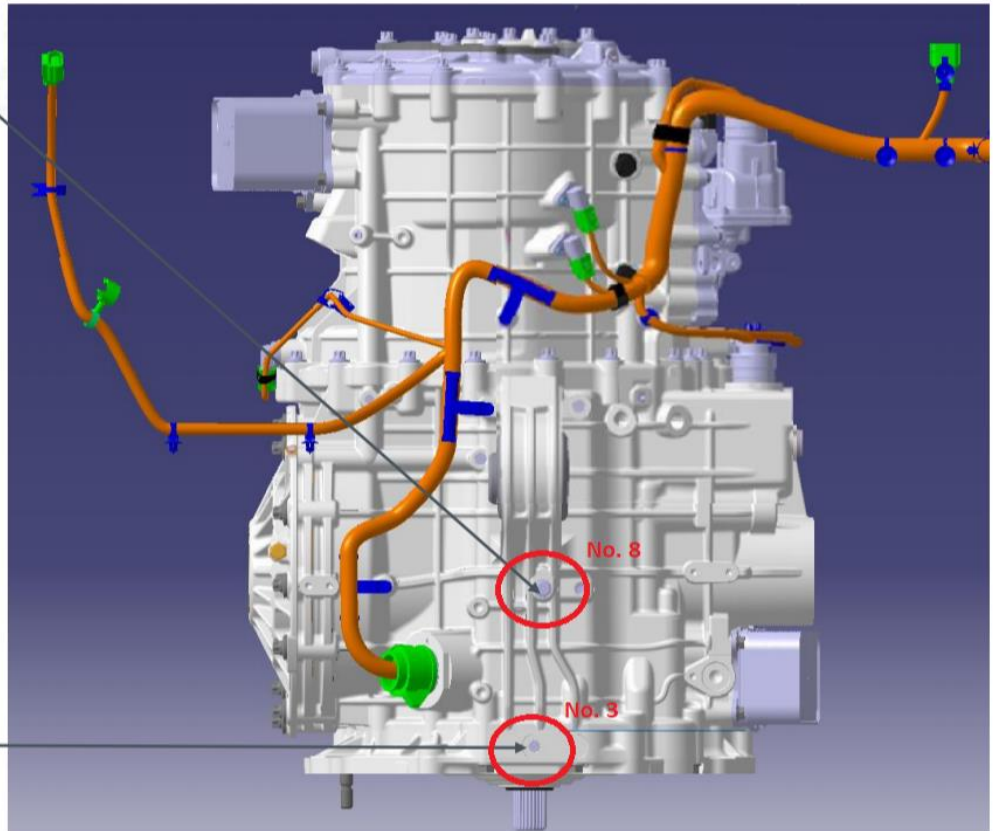

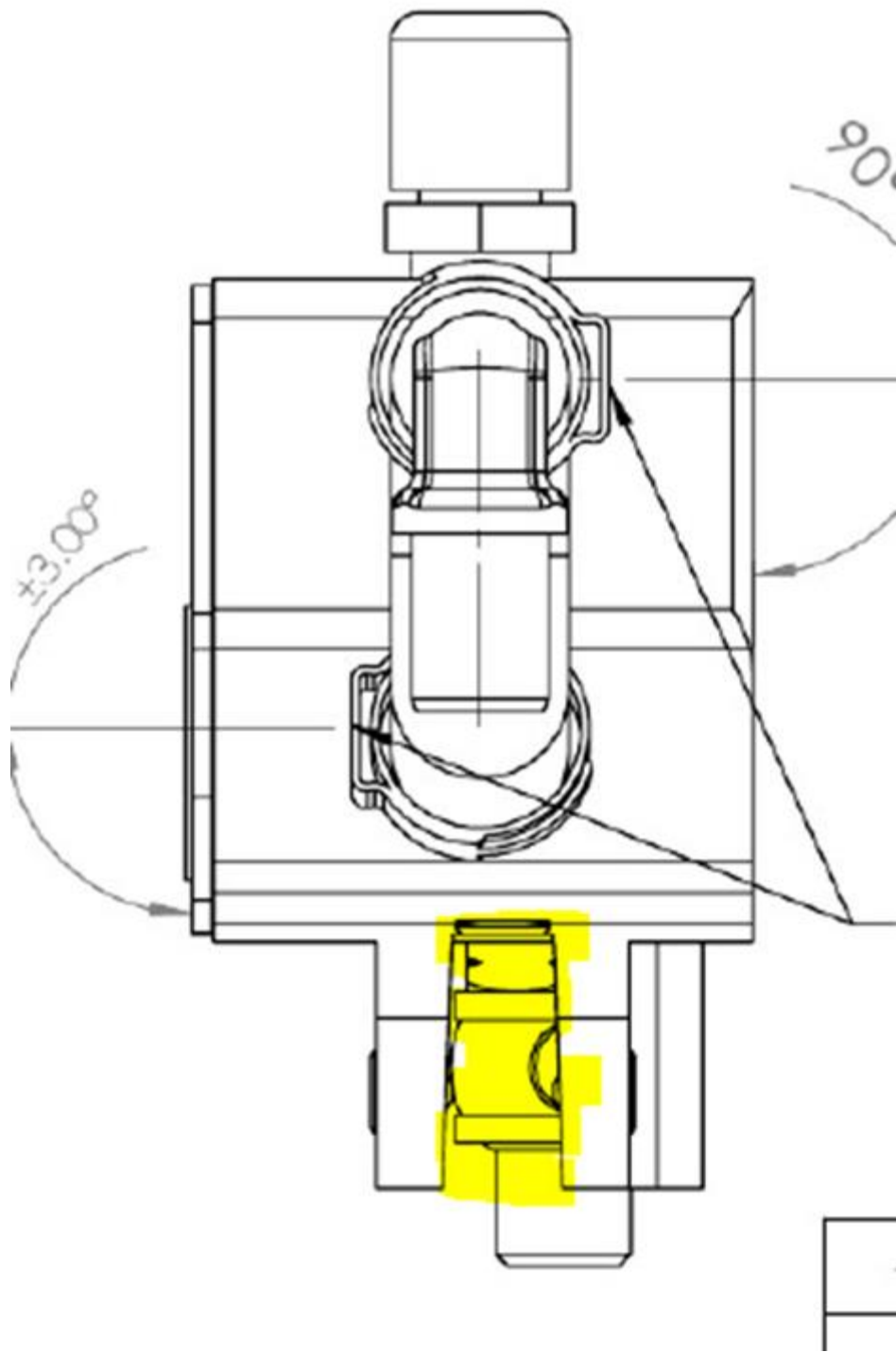

## Parts Information

15GA017CP - TANK ASSY - BREATHER - CLUTCH FLUID

## Warranty Information

If the vehicle is under warranty and you intend to submit a warranty claim for this procedure, Please use the details below.

Causal	Part	Number:	15GA017CP
Causal	Part	Name:	Tank Assy Breather Clutch Fluid
Causal		Issue:	Retrofit
Rectification:			Replace
Time	Claimable:	2.60	hrs

Work Instruction: DA-RM-WA0000-01-032

## Attachments

N/A

## KA Update Information

17/08/2021 KA-Review Q2

**This document is uncontrolled when printed. Before use, check the Knowledge Base within the McLaren Retailer Portal to verify that this is the current version.**