

This document is uncontrolled when printed. Before use, check the Knowledge Base within the McLaren Retailer Portal to verify that this is the current version.

## Document Information

**Location:** Powertrain Systems - HVAC

**Topic:** Water ingress into the passenger or driver foot area

**Condition:** Mainly when HVAC system is in operation

**Diagnostic Trouble Codes :** N/A

## Measure

If presence of water is found in the driver's or passenger's foot area, the water is most likely coming from the HVAC distribution box and its HVAC drain hose. To stop the water leak, the HVAC drain hose must be removed.

Refer to SIS instructions to remove the front luggage bin (and battery if necessary)

P13: CA-RM-07M003-01-001 - Remove/Install Li-Ion battery

P14: DA-RM-07M003-01-001 - Remove/Install Li-Ion battery

P15: EA-RM-07M003-01-001 - Remove/Install Li-Ion Battery

Once you have better access to the HVAC distribution box, locate the HVAC drain hose (see pictures in the attachments area) and remove it from the spigot that is attached to the HVAC distribution box.

**Care Point:** There is no need to remove the spigot.

With the HVAC drain hose removed, the drain water from the HVAC will not be directed to the cabin but it will still exit the car from an area that is designed to be wet.

**Care Point:** The HVAC drain hose and spigot have been permanently removed from all vehicles that leaving the factory since April 2018. As a result, if these parts are found to be missing during inspection, do not order and install them as part of a repair as this is design intent.

## Attachments

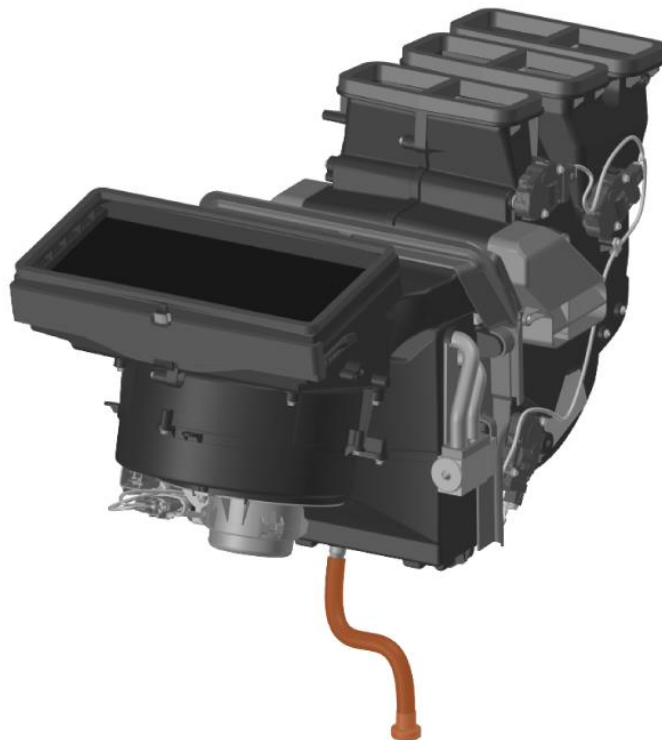

## KA Update Information

18/08/2021 KA- Review Q2

**This document is uncontrolled when printed. Before use, check the Knowledge Base within the McLaren Retailer Portal to verify that this is the current version.**