

This document is uncontrolled when printed. Before use, check the Knowledge Base within the McLaren Retailer Portal to verify that this is the current version.

## Document Information

Location: Infotainment - ADI

Topic: FM/AM Radio Reception Diagnosis

Condition: Permanent

Diagnostic Trouble Codes: N/A

## Measure

The ADI system is equipped with Antenna Reception Strength parameters that are visible within the ADI Actual Values.

Both 720S and Senna vehicles are equipped with one FM/DAB antenna, one FM/AM antenna and one UHF Antenna for Key reception, all housed within the front windscreen.

The radio antennas are connected via amplifiers and transmit signal via coax cables to the Infotainment ECU (ICU). This unit contains the Tuner and it is located in the electric city.

UHF (CL) antenna is connected to an amplifier and transmits signal via Coax cable to the SBC/BC, this amplifier is combined with FM/AM.

The tuner within the ICU is also configurable for different markets, it is possible to change the frequency range and frequency steps via an MDS coding procedure – see KA-01115.

If presented with a complaint of poor FM reception please park the vehicle in an open space outside of workshop that is known to be suitable for radio function test.

1. Tune the radio manually to a known good radio station frequency.
2. Access ADI Actual values and read the following values;

FM1\_S\_Meter\_value\_information\_Read

FM2\_S\_Meter\_value\_information\_Read

AM\_S\_Meter\_value\_information\_Read

3. FM1\_S, FM2\_S and AM\_S will show values for reception strength, if the readings are very low or 0, it is necessary to inspect the antenna connection to their amplifiers, and the amplifier connection to its Coax.
4. If the connections are good check the Fakra connections at the ICU.
5. If the Fakra connections are good, disconnect each end of the relevant coax cable from the amplifier and ICU (See table below) and using a multimeter make continuity tests.
6. If Coax cable is open circuit or with very high resistance, or short circuit to ground make an inspection of the intermediate connections that separate harness sections (see wiring diagram below).
7. If you are unable to identify a section of coax cable that is damaged or defective use a length of thin wire to make a substitution of the windscreen antenna element. Connect the cable directly to the relevant amplifier input, check the actual values to see if the signal is restored or improved.
8. If signal strength has improved take a print of actual values with original screen antenna reconnected and another set with donor wire to show improvement, seek approval to replace the windscreen.
9. If the signal strength is still low ensure the mounting tab of the amplifier is with a good ground, if it is ok change the amplifier and retest.
10. If reception is still poor compared to another vehicle in the same location, and facing in the same direction on the same tuned frequency, please open a TR for further diagnostic assistance.

**Right Drive EU**

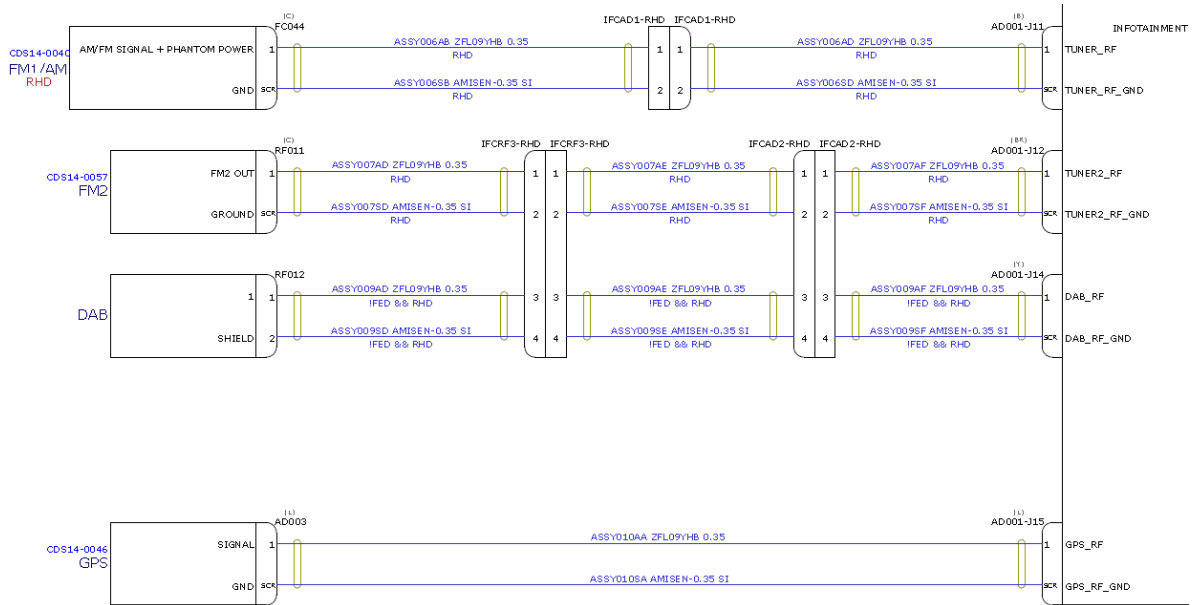

### Left Drive EU / ROW / FED

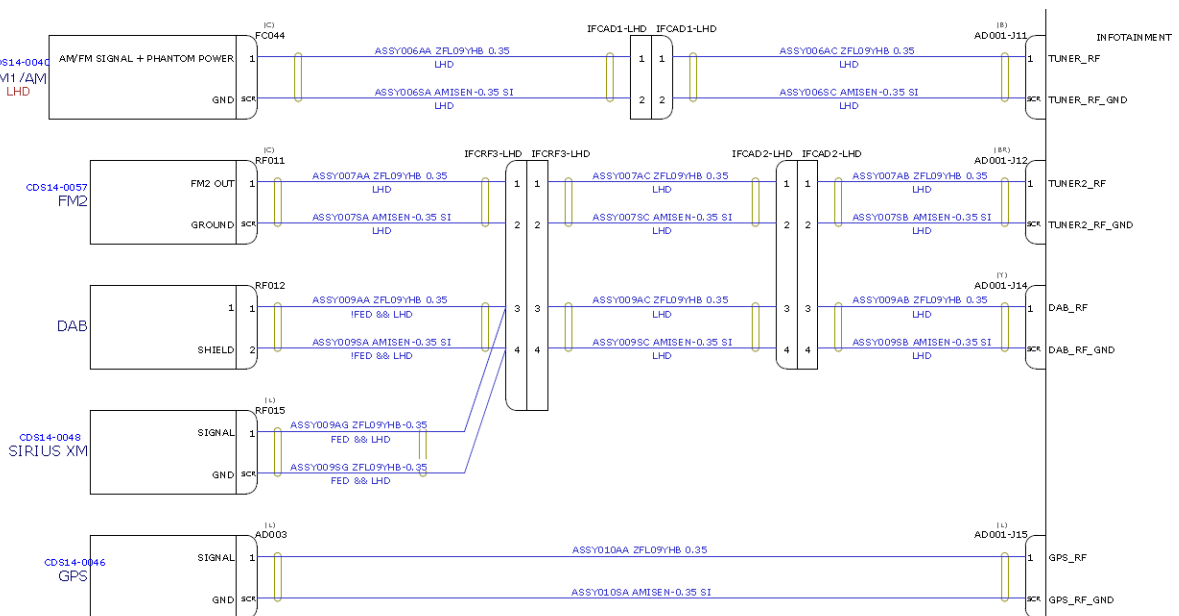

The Coax cables are connected to the amplifiers and the ICU using different colour FAKRA connections.

Antenna / Amplifier Locations:

Function	Location	Amplifier Fakra Colour	ICU Connector Fakra Colour
FM1/AM	"A Post" - opposite side to driver seat, behind interior trim panel.	Beige	J11 / Black
UHF (CL)	"A Post" - opposite side to driver seat, behind interior trim panel.	Grey	To SBC
FM2	Above driver interior mirror assembly / central roof panel.	Beige	J12 / Brown
DAB	Above driver interior mirror assembly / central roof panel.	Curry	J14 / Curry
GPS	Under Dashboard	Blue	J15 / Blue
Sirius XM	Above driver interior mirror assembly / central roof panel.	Curry	J13 / Curry

## Infotainment (ICU)

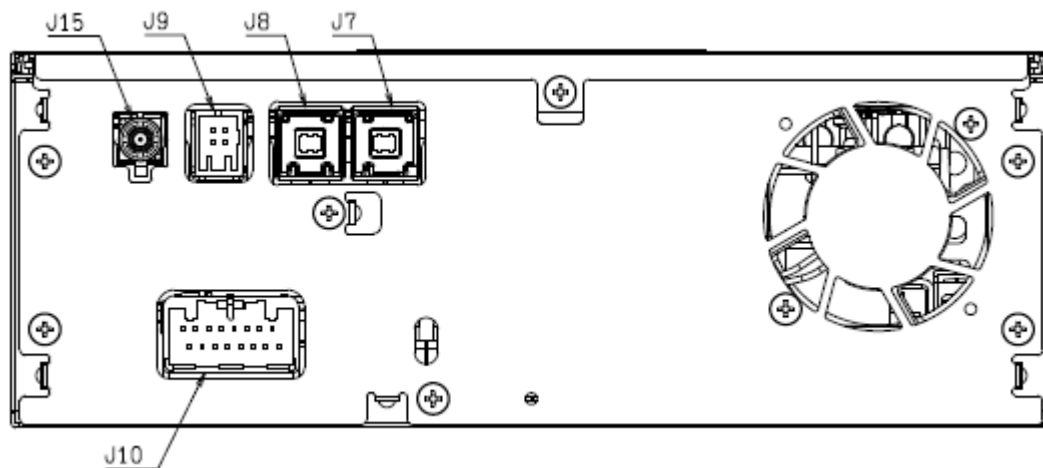
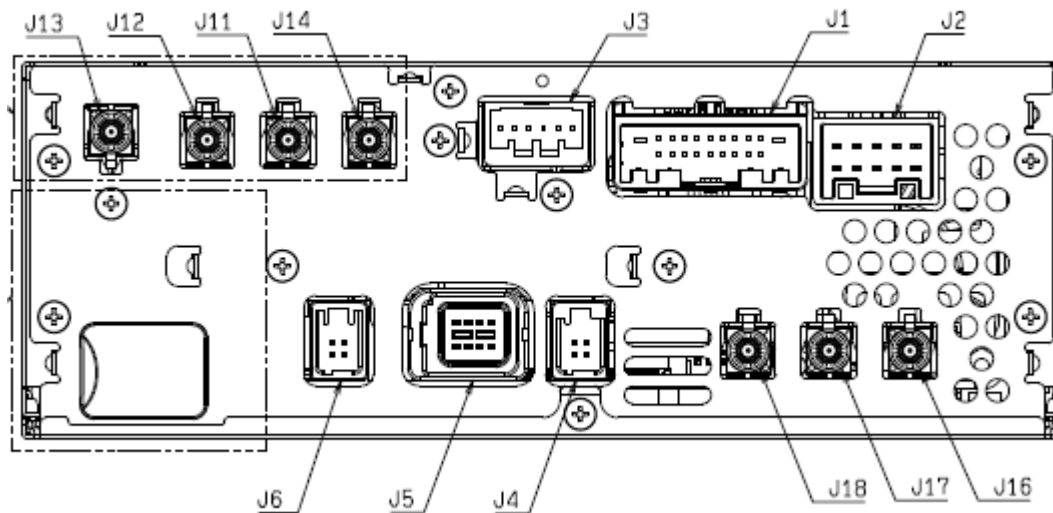

## Parts Information

N/A

## Attachments

N/A

## KA Update Information

21/04/2021 KA Review

This document is uncontrolled when printed. Before use, check the Knowledge Base within the McLaren Retailer Portal to verify that this is the current version.