

## Document Information

**Location:** Body BIW - Active Aero

**Topic:** Airbrake Warning Message on the driver's display and the airbrake is inoperative

**Condition:** During driving the airbrake message is displayed

**Diagnostic Trouble Codes:**

TCU:

C101B92 Airbrake move time out

C101C92 Airbrake movement implausible

C101A94 Airbrake not holding position

## Measure

In the event of an Airbrake Warning Message, please follow the steps below to diagnose the concern:

1. Connect the MDS and save a copy of the TCU actual values in .pdf before you proceed to the next step.
2. Check that the TCU software installed is on the latest 14M0999CP.16 for MY18, or 14M0999CP.22 for MY19.
3. If not, update the software of the TCU with MDS.
4. Remove the Airbrake Panel and disconnect the CHMSL (light). Refer to SIS DA-RM-02A053-03-001 - Remove/Install panel - Airbrake
5. Remove the two M4 bolts (both actuators) from the Position Sensor. It is likely the Position Sensor has already been glued to the Drive Connector / Actuator Pin (this should be true of vehicles manufactured from May 2018) and cannot be independently removed, please continue to Step 10. If the Position Sensor can easily be removed, continue from Step 6.

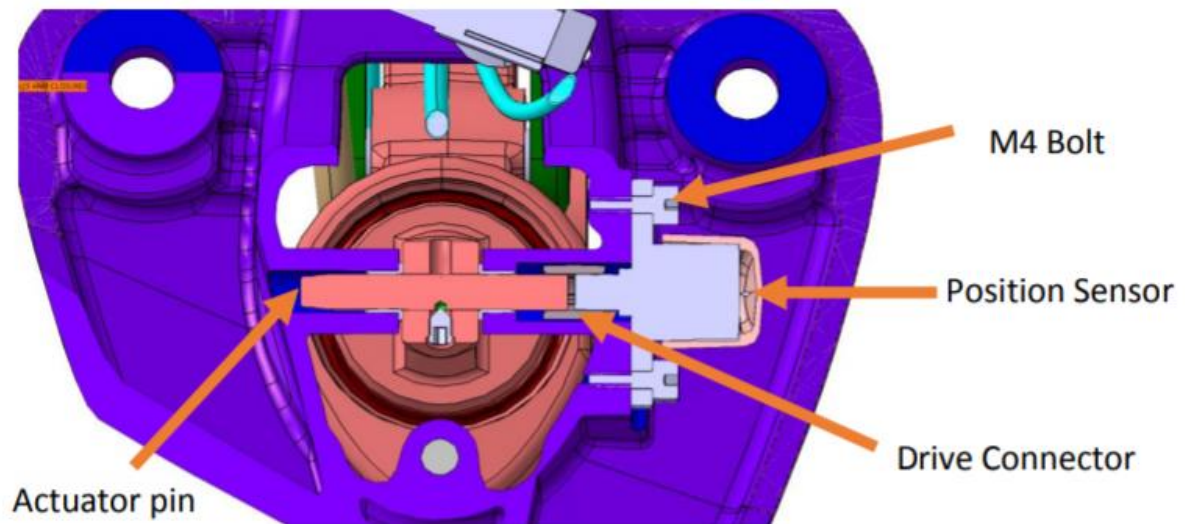

6. Remove the Drive Connector (if not already removed) while keeping the Actuator Pin still assembled to the airbrake mechanism.



7. Inspect and clean any debris or glue residue from the Drive Connector

8. Apply "super glue" (e.g. Loctite 406) to the internal surfaces of the Drive Connector, see image below



9. Install Drive Connector onto Sensor, ensuring any glue squeeze out does not stop the Actuator Sensor from functioning (rotating). While the glue is still wet on the inside of the Drive Connector (add more glue if necessary), reinstall the sensor to the airbrake mechanism ensuring a good fit with the drive connector

10. Correctly align the Actuator Sensor (with the sensor cable extending out the top of the sensor) and re-tighten the 2 x M4 screws to  $4\text{Nm} \pm 0.5\text{Nm}$

11. Re-assemble the airbrake panel and brake light connector

**Care Point:** Do not induce any push or pull forces (tension) between the 2 actuators once the airbrake panel is fixed on them. This can alter their internal friction characteristics and affect their relative movement speed.

12. Replace airbrake panel fixing bolts every time they are removed. Tighten and torque to  $14\text{Nm} \pm 1.4\text{Nm}$  following below sequence A - F.

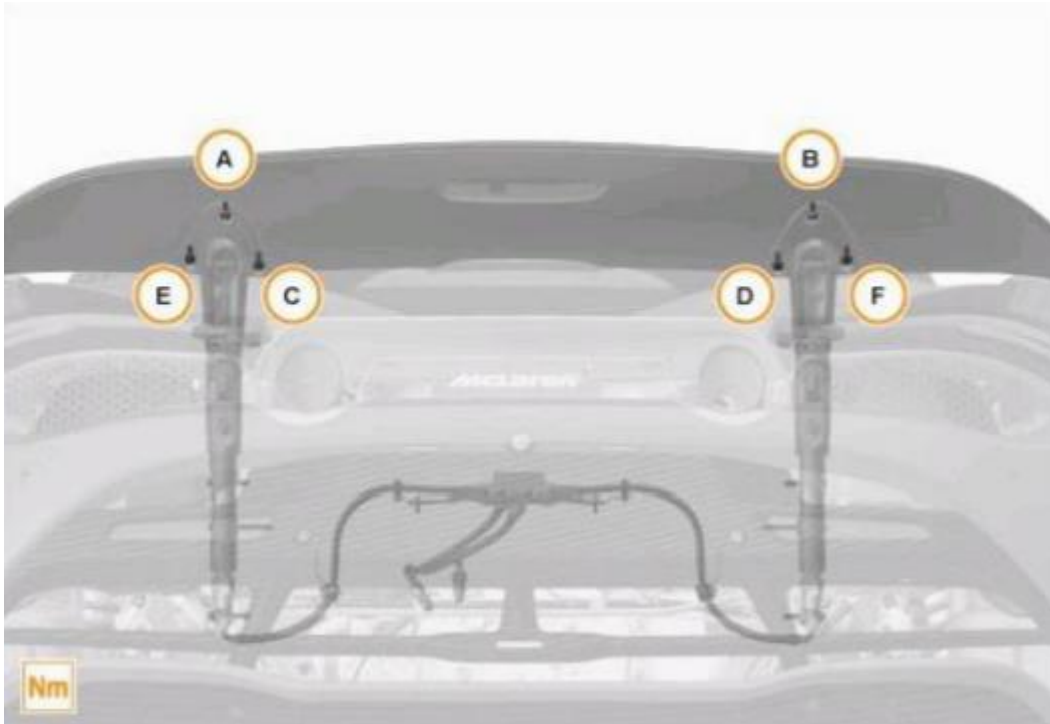

13. Run the airbrake bleed sequence in TCU. Repeat the sequence 3 times sleeping the car between each bleed

14. Run the calibration sequence. Once the calibration is completed check the following actual values - those are the calibrated values

vRearWingLift2MinLH - the value range should be between 0.00 to 9.99

vRearWingLift1MinRH - the value range should be between 0.00 to 9.99

vRearWingLift2MaxLH - the value range should be between 147.00 to 152.00

vRearWingLift1MaxRH - the value range should be between 147.00 to 152.00

The airbrake position sensor tolerances are the following:

	Lower Limit	Nominal Position	Upper Limit
Minimum lift (0%)	0.00 mm	0.00 mm	9.99 mm
Maximum lift (100%)	147.00 mm	152.00 mm	152.00 mm

If the position sensors are still outside the above specification, continue with Step 15 to replace the sensors, pins and connectors. If this has not solved the issue, please raise a Technical Request and provide all the information requested in this KA.15.

15. Remove the Airbrake Panel and disconnect the CHMSL (light). Refer to SIS DA-RM-02A053-03-001 - Remove/Install panel - Airbrake

16. Remove the two M4 bolts (both actuators) from the Position Sensor

17. Remove the grub screw (access from the rear of the airbrake mounting plate)

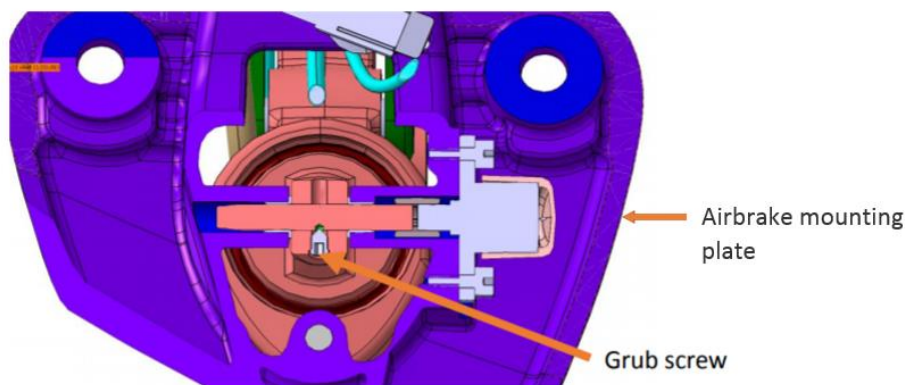

18. Push the actuator pin from one side to slide it out from the other side of the airbrake mounting plate

19. Replace actuator pin and drive connector using parts from kit (14A0082CP) and Position Sensors (14A0434CP)

20. Locate the airbrake mounting plate back on the top of the actuator and align the holes so that the new actuator pin can be inserted through smoothly

21. Reinstall the actuator pin. The flat surface of the pin should be facing up and slightly towards the rear of the car - see picture below. This will ensure that when the actuator pin is fully inserted the grub screw threads will be visible and aligned with the hole at the back of the airbrake mounting plate to allow the grub screw to be re fitted



Care Point: When re-inserting the actuator pins, ensure the 2 top hat spacers are in place. If they are not present please order the airbrake repair kit from SPC - part number: 14A0082CP

22. Once in place push the actuator pin back in position



23. The threads for the grub screw on the side of the actuator pin will now be aligned with the hole at the back of the airbrake mounting plate



24. Tighten the grub screw to secure the actuator pin in position to 2.5 Nm +/- 0.3Nm

25. Go back and continue from Step 6-14.

## Parts Information

N/A

## Warranty Information

Resolution Category

Casual Part Number: 14A0434CP

Casual Part Name: POSITION SENSOR VARIOHM VERT X

Casual Issue: Modification

Rectification: Repair

Time: 1.00

## Attachments

N/A

## KA Updates Information

07/02/2019 Procedure Revision - Glue drive connector to sensor and actuator pin

16/03/2019 Step 14: actual values descriptions corrected

**This document is uncontrolled when printed. Before use, check the Knowledge Base within the McLaren Retailer Portal to verify that this is the current version.**