

Document Information

This document is uncontrolled when printed. Before use, check the Knowledge Base within the McLaren Retailer Portal to verify that this is the current version.

Vehicles affected: P14: 720S, 720S Spider

Location: Powertrain - Engine

Concern: Rattle from engine bay

Condition: Idle to 2500rpm

Diagnostic Trouble Codes

N/A

Measure

At engine speed up to 2500rpm it may be possible to hear a rattle noise coming from the engine bay area, especially if the door window is open.

The noise is more prevalent from the left hand side of the vehicle due to the orientation of the turbo.

This rattle is due to clearances within the turbo wastegate valve assembly - highlighted in the image below - and is present when the wastegate valve is in the open position.

At 1800rpm the wastegate valve will be held closed, which reduces the audible rattle.

These clearances are required to allow for heat expansion of the multiple materials used and their different heat expansion rates.

As a result of this design, the tolerance cannot be changed and the resultant rattle is a characteristic of the assembly design.

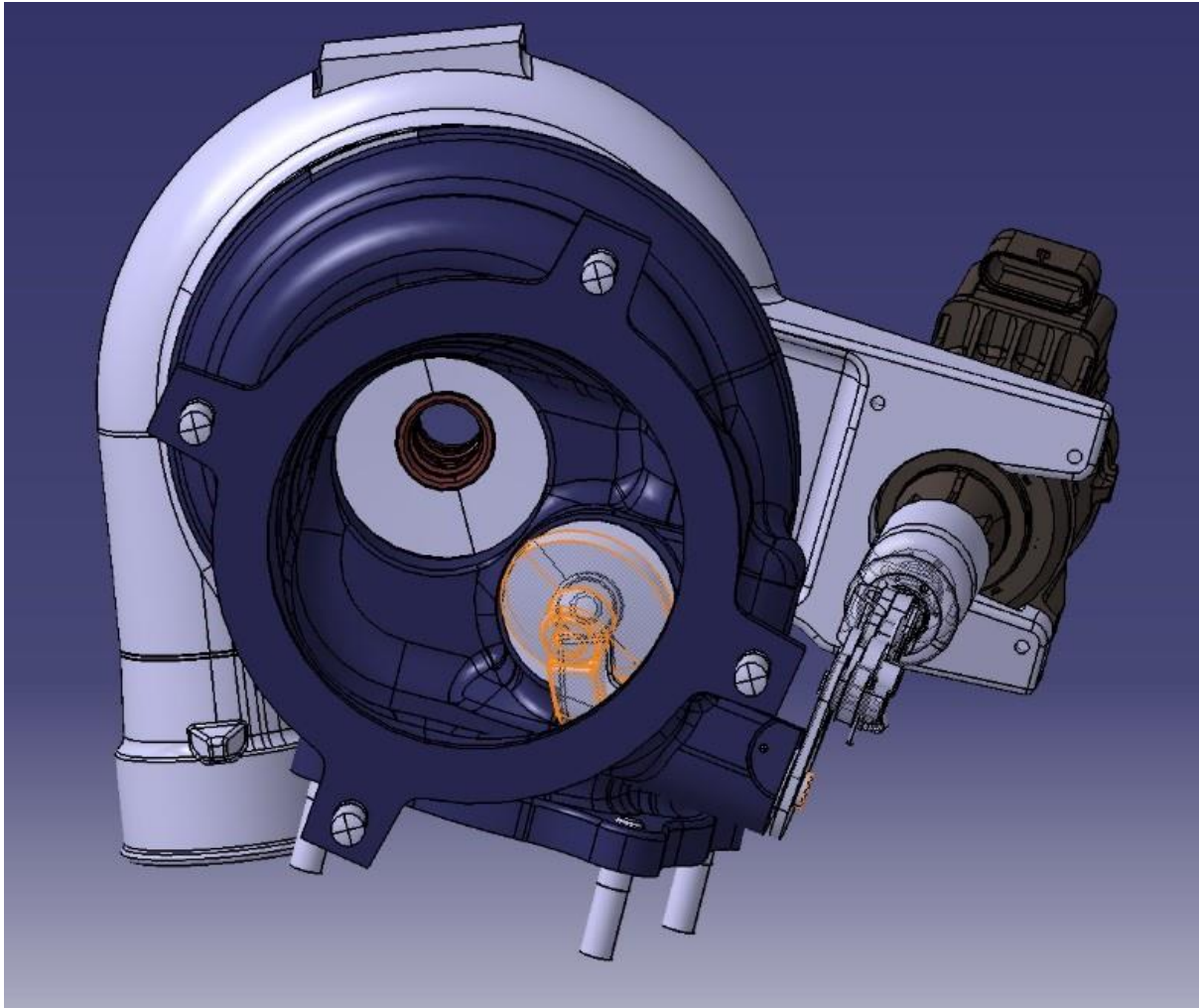

In the attached video, the described rattle is demonstrated by rotating the valve.

Attachments

MTI Updates Information

N/A

This document is uncontrolled when printed. Before use, check the Knowledge Base within the McLaren Retailer Portal to verify that this is the current version.